

Introduction

The DT35 and DT55 series full-circle/adjustable part-circle rotary sprinklers are designed specifically for golf course applications.

Manufactured from durable, high-strength engineering plastic and stainless-steel components, these sprinklers incorporate many innovative and time-proven features for lasting, maintenance-free operation.

Prior to installing the sprinkler, read through the recommended installation and start-up procedures. Please observe all **WARNINGS** and **CAUTIONS** when installing and operating this equipment.

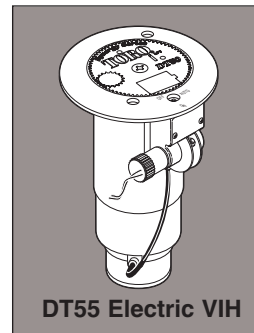
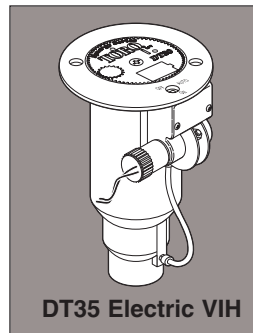

Features

- Full-circle (360°) with uni-directional clockwise rotation and adjustable part-circle (40°–330°) configuration
- Arc adjustment from riser band in 5° increments
- Trajectory main nozzle - Selectable 15° or 25°
- Full 4" (10.2 cm) pop-up clears tall grasses
- Color-coded nozzles by radius and gallonage
- Cap serves as an effluent water indicator
- Variable stator ensures 3-minute rotation
- Selectable pressure regulation settings of 50 psi (3.4 bar), 65 psi, 80 psi or 100 psi to ensure consistently accurate nozzle performance regardless of elevation (Electric only)
- Three valve activation types available: Electric Valve-In-Head, Normally Open Hydraulic Valve-In-Head, and Check-O-Matic
- Three valve activation types available: Electric Valve-In-Head, Normally Open Hydraulic Valve-In-Head, and Check-O-Matic
- Three body thread types available: NPT, BSP and ACME
- Manual sprinkler operation control: On-Off-Auto (Electric only)
- All internal components serviceable from the top of the sprinkler
- Large selection of color-coded nozzles available
- Durable plastic and stainless-steel construction
- Constant velocity drive
- Optional back nozzles available
- Color-coordinated nozzles
- Optional radius reduction screw

Specifications and Performance/Application Data

DT35 Series

- Radius: 43'–88' (13,1 m–26,8 m) @ 25° trajectory
- Flow Rate: 15–50 GPM (56,8–189,3 LPM)
- Trajectory: Selectable 15° or 25°
- Arc: full circle (360°) or adjustable part circle (40°–330°)
- Recommended operating pressure: 65–100 psi (4,5–6,9 bar)
- Minimum pressure: 40 psi (2,8 bar)
- Maximum pressure: 150 psi (10,3 bar)
- Precipitation rate:
 - Minimum: 0.46"/hr (1,17 cm/hr)
 - Maximum: 0.63"/hr (1,60 cm/hr)
- Inlet Size: 1" (25 mm) NPT, BSP or ACME
- Electric Valve-in-head Solenoid:
 - Inrush current: 0.30A @ 24 VAC, 50/60 Hz
 - Holding current: 0.20A @ 24 VAC, 50/60 Hz
- Check-O-Matic model checks up to 37' (11,27 m) of elevation

DT55 Series

- Radius: 52'–95' (15,8–28,9 m) @ 25° trajectory
- Flow rate: 15–62 GPM (56,8–234,7 LPM)
- Trajectory: Selectable 15° or 25°
- Arc: full circle (360°) or adjustable part circle (40°–330°)
- Recommended operating pressure: 65–100 psi (4,5–6,9 bar)
- Minimum pressure: 40 psi (2,8 bar)
- Maximum pressure: 150 psi (10,3 bar)
- Precipitation rate:
 - Minimum: 0.50"/hr (1,27 cm/hr)
 - Maximum: 0.72"/hr (1,83 cm/hr)
- Inlet Size: 1.5" (38 mm) NPT, BSP or ACME
- Electric Valve-in-head Solenoid:
 - Inrush current: 0.30A @ 24 VAC, 50/60 Hz
 - Holding current: 0.20A @ 24 VAC, 50/60 Hz
- Check-O-Matic model checks up to 37' (11,27 m) of elevation

DT35 Series Sprinkler Performance Data

Base Pressure	Nozzle Set 30 ● (Plug)		Nozzle Set 31 ● (Yellow)		Nozzle Set 32 ● (Blue)		Nozzle Set 33 ● (Brown)		Nozzle Set 34 ● (Orange)		Nozzle Set 35 ● (Green)		Nozzle Set 36 ● (Gray)		Nozzle Set 37 ● (Black)	
	▲BIEGE	★YELLOW	▲PLUG	⊗GREEN	▲YELLOW	★YELLOW	▲YELLOW	★YELLOW	▲YELLOW	★YELLOW	▲GREEN	★YELLOW	▲GREEN	⊗GREEN	▲GREEN	⊗GREEN
psi	Radius	GPM	Radius	GPM	Radius	GPM	Radius	GPM	Radius	GPM	Radius	GPM	Radius	GPM	Radius	GPM
50	43	8.2	53	13.2	58	16.6	63	22.3	65	26.4						
65	45	10.0	55	15.0	60	21.0	65	25.0	70	29.0	74	36.0				
80	46	11.5	58	16.5	64	22.1	69	27.4	73	32.2	77	39.4	80	44.0	85	47.0
100	47	13.4	60	18.4	69	24.7	73	30.3	76	36.0	80	43.5	83	49.0	88	51.5

DT55 Series Sprinkler Performance Data

Base Pressure	Nozzle Set 51 ● (Yellow)		Nozzle Set 52 ● (Blue)		Nozzle Set 53 ● (Brown)		Nozzle Set 54 ● (Orng)		Nozzle Set 55 ● (Green)		Nozzle Set 56 ● (Gray)		Nozzle Set 57 ● (Black)		Nozzle Set 58 ● (Red)		Nozzle Set 59 ● (Beige)	
	▲PLUG	⊗GREEN	▲YLW	★YELLOW	▲YLW	★YELLOW	▲YLW	★YELLOW	▲GREEN	★YELLOW	▲GREEN	⊗GREEN	▲GREEN	⊗GREEN	▲BLUE	⊗GREEN	▲BLUE	⊗GREEN
psi	Radius	GPM	Radius	GPM	Radius	GPM	Radius	GPM	Radius	GPM	Radius	GPM	Radius	GPM	Radius	GPM		
50	53	13.2	58	16.6	63	22.3	65	26.4										
65	55	15.0	60	21.0	65	25.0	70	29.0	74	36.0								
80	58	16.5	64	22.1	69	27.4	73	32.2	77	39.4	80	44.0	85	47.0	90	50.0	92	57.5
100	60	18.4	69	24.7	73	30.3	76	36.0	80	43.5	83	49.0	88	51.5	93	54.5	95	62.0

Radius shown in feet.

Toro recommends the use of a 1/4" (30mm) swing joint at flows over 25 GPM (95 LPM). Sprinkler radius of throw per ASAE standard S398.1

● = Main Nozzle ▲ = Intermediate Nozzle ★ = Inner Nozzle (Yellow w/ White Restrictor) ⊗ = Inner Nozzle (Green w/ White Restrictor)

All sprinklers are equipped with the selectable pilot valve that allows settings at 50, 65, 80 and 100 psi.

DT35/DT55 SR Series Nozzle Performance Chart—U.S.

Base Pressure	Nozzle Set Main - Plug		Nozzle Set Main - Plug		Nozzle Set Main - Plug		Nozzle Set Main - Plug		Nozzle Set Main - Plug	
	▲ BLUE	■ GRAY	▲ ORNG	■ GRAY	▲ RED	■ GRAY	▲ GRAY	■ GRAY	● GRAY	■ GRAY
psi	Radius	GPM	Radius	GPM	Radius	GPM	Radius	GPM	Radius	GPM
65	46'	8.7	46'	10.4	50'	12.4	42'	10.2	47'	13.9
SOR	5:02 minutes		4:16 minutes		3:36 minutes		4:19 minutes		4:06 minutes	
80	46'	9.6	47'	11.5	53'	13.7	44'	11.2	51'	15.3
SOR	4:22 minutes		3:40 minutes		3:03 minutes		3:53 minutes		3:40 minutes	

▲ = Intermediate Nozzle ■ = Inner Nozzle ● = Main Nozzle w/o Restrictor

SR = Short Range SOR = Speed of Rotation

DT35 & DT55 Back Nozzle Performance Chart—U.S.

Part#	Nozzles Restrictor	Color	65 PSI		80 PSI		Profile
			Radius	GPM	Radius	GPM	
89-4785	NO	Green	25	1.7	25	1.9	
102-2135	102-1124 (Large White Included)	White	25	4.1	26	4.5	
102-2136	102-2041 (Yellow Included)	Yellow	24	3.8	25	4.1	
89-3942	89-4649 (Black Required)	Blue	23	2.4	24	2.4	
89-4652	89-4650 (Small White Required)	Brown	30	3.1	30	3.5	
89-3942	NO	Blue	36	3.4	36	3.7	
89-4738	NO	Red	29	3.5	31	3.8	
89-4651	NO	Yellow	34	2.6	36	2.9	
89-4652	NO	Brown	34	3.8	34	4.4	
89-3729	NO	Ornge	33	4.0	34	4.5	
89-4653	NO	Green	32	4.1	32	4.8	
89-1879	NO	Gray	35	4.8	36	5.0	
89-4654	NO	Black	32	4.7	32	5.1	
89-1878	NO	Red	36	4.7	36	5.2	
102-2925	NO	Blue	40	2.9	40	3.1	
102-2926	NO	Orange	43	4.2	43	4.4	
102-2927	NO	Gray	46	4.6	47	4.9	
102-2928	NO	Red	50	5.7	52	6.3	
102-2929	NO	Beige	48	7.2	53	8.1	

DT35 Series Trajectory Performance Chart—U.S.

Nozzle / PSI / GPM	#31 Nozzle @ 65 PSI, 15.0 GPM				#32 Nozzle @ 65 PSI, 21.0 GPM				#33 Nozzle @ 65 PSI, 25.0 GPM			
Trajectory			15°	25°			15°	25°			15°	25°
A (Radius)			50'	55'			51'	60'			59'	65'
B (Spray Height)			5'	11'			6'	12'			7'	13'
C (Distance from Head)			26'	33'			28'	34'			32'	35'

Nozzle / PSI / GPM	#34 Nozzle @ 65 PSI, 29.0 GPM				#35 Nozzle @ 65 PSI, 36.0 GPM				#36 Nozzle @ 80 PSI, 44.0 GPM			
Trajectory			15°	25°			15°	25°			15°	25°
A (Radius)			63'	70'			64'	74'			73'	80'
B (Spray Height)			6'	14'			7'	15'			8'	17'
C (Distance from Head)			35'	39'			36'	43'			40'	45'

Nozzle / PSI / GPM	#37 Nozzle @ 80 PSI, 47.0 GPM			
Trajectory			15°	25°
A (Radius)			72'	85'
B (Spray Height)			8'	18'
C (Distance from Head)			39'	46'

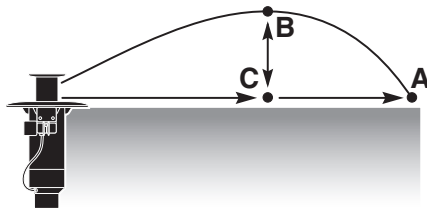

A = Radius
B = Spray Height
C = Spray Height Distance From Head

DT55 Series Trajectory Performance Chart—U.S.

Nozzle/PSI/GPM	#51 Nozzle @ 65 PSI, 15.0 GPM				#52 Nozzle @ 65 PSI, 21.0 GPM				#53 Nozzle @ 65 PSI, 25.0 GPM			
Trajectory			15°	25°			15°	25°			15°	25°
A (Radius)			51'	55'			51'	60'			59'	65'
B (Spray Height)			6'	13'			6'	11'			7'	13'
C (Distance from Head)			32'	40'			31'	34'			32'	37'

Nozzle/PSI/GPM	#54 Nozzle @ 65 PSI, 29.0 GPM				#55 Nozzle @ 65 PSI, 36.0 GPM				#56 Nozzle @ 80 PSI, 44.0 GPM			
Trajectory			15°	25°			15°	25°			15°	25°
A (Radius)			63'	70'			66'	74'			75'	80'
B (Spray Height)			8'	15'			9'	15'			8'	18'
C (Distance from Head)			40'	41'			43'	45'			44'	47'

Nozzle/PSI/GPM	#57 Nozzle @ 80 PSI, 47.0 GPM				#58 Nozzle @ 80 PSI, 50.0 GPM				#59 Nozzle @ 80 PSI, 57.5 GPM			
Trajectory			15°	25°			15°	25°			15°	25°
A (Radius)			74'	85'			82'	90'			81'	92'
B (Spray Height)			9'	19'			10'	18'			11'	21'
C (Distance from Head)			41'	45'			43'	45'			49'	49'

Sprinkler Spacing Guidelines

■ Square Spacing

- No wind - 55% of diameter
- 4 mph wind - 50% of diameter
- 8 mph wind - 45% of diameter

■ Triangular Spacing

- No wind - 60% of diameter
- 4 mph wind - 55% of diameter
- 8 mph wind - 50% of diameter

■ Single-Row Spacing

- No wind - 50% of diameter
- 4 mph wind - 50% of diameter
- 8 mph wind - 45% of diameter

Note: Designing for zero (0) mph wind conditions is not recommended. Design for worst wind conditions.

For additional information, refer to Toro Technical Data Manual, form number 490-1737.

Precipitation Rate Formulas

■ Square-spaced sprinklers in pattern:

$$\frac{\text{GPM of full circle} \times 96.3}{(\text{Spacing})^2}$$

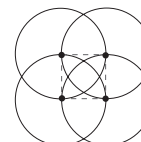

■ Triangular-spaced sprinklers in pattern:

$$\frac{\text{GPM of full circle} \times 96.3}{(\text{Spacing})^2 (0.866)}$$

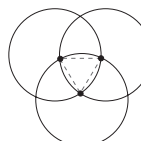

■ Area and flow:

$$\frac{\text{Total GPM of zone} \times 96.3}{\text{Total irrigated square feet of zone}}$$

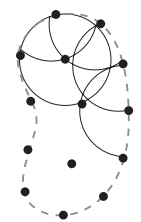

■ Single row:

$$\frac{\text{GPM of full circle} \times 96.3}{(\text{Spacing}) (\text{Scallop})}$$

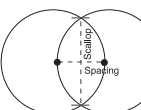

Installation Procedure

To assure maximum performance from your 800S series sprinklers, read these instructions completely prior to installation or service.

Constructing Swing Joints

1. Construct or provide triple swing joints for each sprinkler as shown in **Figure 1**. Use PVC or ABS pipe nipple for the sprinkler connection.

Note: On sites where the possibility of heavy equipment rolling over a sprinkler exists, the swing joint will flex preventing damage to the lateral or main lines. On a new installation in raw ground where the sprinklers are to be initially installed above the finished grade and lowered when new turf is established, the swing joint allows sprinkler repositioning without changing risers. This is a common and practical procedure which eliminates the problem of dirt being accidentally introduced into the lateral lines when a riser is changed.

2. Flush lines thoroughly prior to installing sprinkler.
3. Apply PTFE tape on riser threads (not required on ACME threads). Install sprinkler to the riser and tighten.

▲ CAUTION: Use only PTFE tape on riser threads. Use of pipe dope or other types of sealing compounds can cause deterioration of sprinkler body threads.

Figure 1

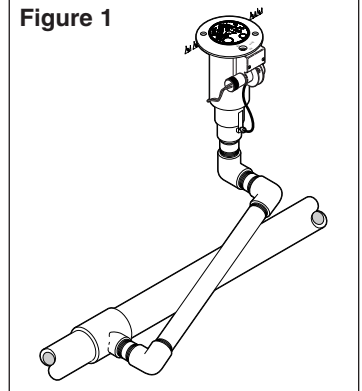

Connecting Control Wires (Electric Models Only)

1. Route control wires to sprinklers. Provide extra wire at sprinkler to allow for height adjustment. One common wire and station wire is required for each sprinkler. See Wire Sizing Chart, **Table 1** for proper application.

Table 1: Wire Sizing Chart

Voltage	AWG	mm ²	Voltage Drop	Circular Mills	Total Wire Length Between Controller and Sprinkler							
					1 Sprinkler		2 Sprinklers		3 Sprinklers		4 Sprinklers	
23	14/14	2.5/2.5	4	4100	3285'	1001 m	1642'	500 m	1095'	334 m	821'	250 m
23	14/12	2.5/4.0	4	5315	4259'	1298 m	2129'	649 m	1419'	432 m	1064'	324 m
23	14/10	2.5/5.5	4	7250	5809'	1770 m	2904'	885 m	1936'	590 m	1452'	443 m
23	12/12	4.0/4.0	4	6530	5232'	1595 m	2616'	797 m	1744'	531 m	1308'	399 m
23	12/10	4.0/5.5	4	8465	6783'	2067 m	3391'	1033 m	2261'	689 m	1695'	517 m
23	12/8	4.0/7.0	4	11515	9227'	2812 m	4613'	1406 m	3075'	937 m	2306'	703 m
23	10/10	5.5/5.5	4	10400	8333'	2540 m	4166'	1270 m	2778'	846 m	2083'	635 m
24	14/14	2.5/2.5	5	4100	4106'	1251 m	2053'	626 m	1369'	417 m	1026'	313 m
24	14/12	2.5/4.0	5	5315	5323'	1622 m	2662'	811 m	1774'	541 m	1331'	406 m
24	14/10	2.5/5.5	5	7250	7261'	2213 m	3631'	1106 m	2420'	738 m	1815'	553 m
24	12/12	4.0/4.0	5	6530	6540'	1993 m	3270'	996 m	2180'	664 m	1635'	498 m
24	12/10	4.0/5.5	5	8465	8478'	2584 m	4239'	1292 m	2826'	861 m	2119'	646 m
24	12/8	4.0/5.5	5	11515	11533'	3515 m	5766'	1757 m	3844'	1172 m	2883'	879 m
24	10/10	10/10	5	10400	10416'	3175 m	5208'	1587 m	3472'	1058 m	2604'	790 m

Note: Wire length data provided in **Table 1** is the sum of the station and common wire legs. See example in **Figure 2**.

2. Attach control wires to solenoid leads using an approved waterproof splicing method.

▲ CAUTION: All wire splices and field connections must be waterproofed to prevent short circuit to ground and subsequent controller damage.

Figure 2

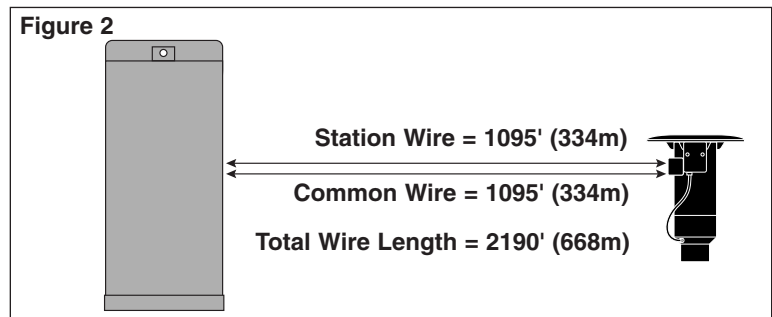

Connecting Hydraulic Control Tubing (Hydraulic Models Only)

1. Route control tubing from the controller to the sprinkler location(s).

Note: Leave an 18" (45.7 cm) service loop of tubing at each sprinkler to facilitate movement of sprinkler and service operations. Refer to **Table 2** for tubing run length and sprinkler elevation information.

2. Flush tubing thoroughly to remove all air and debris.
3. Remove the tube retainer and poly cap from the tubing adapter at the base of the sprinkler.
4. Slide the tube retainer over the end of the control tubing and attach tubing to adapter.
5. Slide tube retainer over the adapter area to secure tubing.

Table 2: Hydraulic Control Systems

Type of System*	Maximum Distance From Controller	Elevation Restrictions
Normally Open (01) with 3/16" Control Tubing	500'	Valve elevation should not exceed 25' ABOVE controller elevation or 70' BELOW controller elevation.
Normally Open (01) with 1/4" Control Tubing	1000'	Valve elevation should not exceed 25' ABOVE controller elevation or 70' BELOW controller elevation

- * All hydraulic connections on Toro valves are 1/4" insert type.
- Control line pressure must be equal to or greater than mainline pressure.
- Control line pressure range is 40 to 150 PSI.

System Start Up



WARNING

TO PREVENT POSSIBLE SERIOUS INJURY, DO NOT STAND OR LEAN DIRECTLY OVER ANY SPRINKLER WHEN FILLING SYSTEM OR WHEN ACTIVATING MANUALLY AT THE SPRINKLER.

The following is a recommended procedure that will protect system components during system start-up. The procedure is based on a velocity fill rate of less than 2' (0.61 m) per second. See **Table 3** below.

1. Use jockey pump only to fill the system at a velocity fill rate of less than 2' (0.61 m) per second.
▲ CAUTION: Failure to comply with recommended fill rate will increase line pressure resulting in a water hammer effect that could damage sprinklers and piping components.
2. Use quick coupler keys at all tees and greens with quick coupler valves to bleed air from the system lines during the filling process. For best results, do not compress air and then relieve it – bleed the air continuously while filling the system.
3. After water has filled all lines and all air is removed, remove the quick coupler keys.

Table 3: Recommended System Fill Rate

Pipe Size		Flow		Velocity		Pipe Size		Flow		Velocity	
in.	cm	GPM	LPM	ft/sec	m/sec	in.	cm	GPM	LPM	ft/sec	m/sec
1/2	1.3	2	7.6	1.60	0.49	3	7.6	45	170.3	1.86	0.57
3/4	1.9	3	11.4	1.92	0.59	4	10.1	75	283.9	1.87	0.57
1	2.5	5	18.9	1.50	0.46	6	15.2	150	567.8	1.73	0.53
1-1/4	3.1	10	37.9	1.86	0.57	8	20.2	250	946.3	1.70	0.52
1-1/2	3.8	10	37.9	1.41	0.43	10	25.4	450	1703.0	1.97	0.60
2	5.0	20	75.7	1.80	0.55	12	30.5	500	1893.0	1.55	0.47
2-1/2	6.4	30	113.6	1.84	0.56						

Arc Adjustment Procedure



WARNING

DUE TO THE HIGH OPERATING PRESSURE, NEVER STAND OR LEAN DIRECTLY OVER THE TOP OF THE SPRINKLER OR COME IN CONTACT WITH THE SPRAY. FAILURE TO COMPLY MAY RESULT IN SERIOUS INJURY.

The DT35 and DT55 sprinkler models can be operated in full-circle or part circle operation. In part-circle operation, the sprinkler arc can be adjusted from 40°–330° (factory preset at 180°). The left side of the arc, located at the end of the counterclockwise rotation, is non-adjustable (fixed). Therefore, all arc adjustments, whether increasing or decreasing, will change the right side of the arc, located at the end of the clockwise rotation. When full-circle (360°) operation is selected, the sprinkler will rotate in a clockwise direction only.

1. Insert the multi-purpose tool (P/N 995-83) into the slot provided in the top of the cap. Pull the riser assembly up, then grasp the assembly to hold it in the popped-up position. See **Figure 3**.
2. Find the sprinkler left stop by rotating the turret counterclockwise until it stops. The left stop indicates the fixed stop of the arc. See **Figure 4**.
3. Find the sprinkler right stop by rotating the turret clockwise until it stops. See **Figure 5**.

Note: If the sprinkler is set at 360° (full-circle), there will be no stop when turning clockwise.

4. Adjust the arc while the turret is pointing at the right stop. Hold the sprinkler riser firmly while pressing the release on the adjustment band. Rotate the turret counterclockwise or clockwise to the desired right stop. See **Figure 6**.

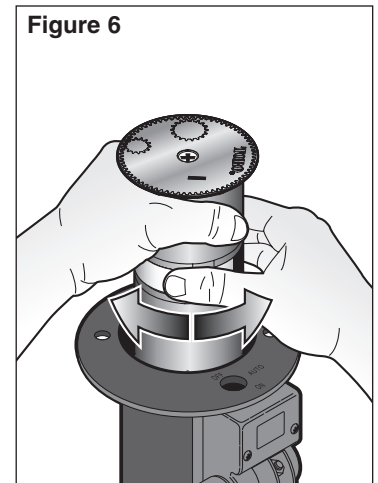
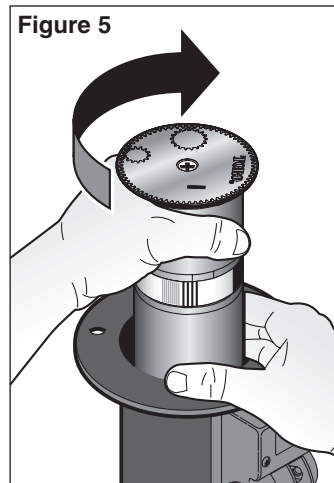
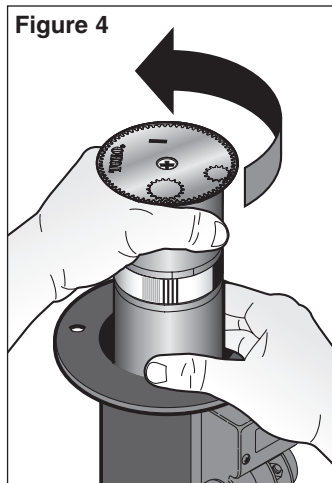
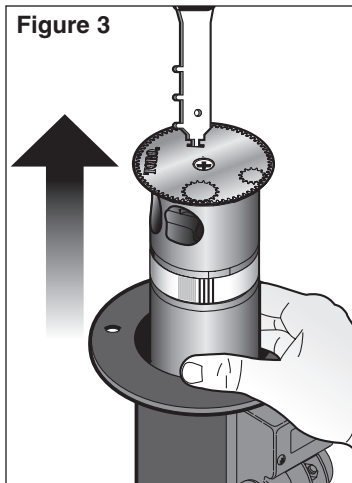

The adjustment band of the DT35 and DT55 have markers at predetermined arcs. By aligning the adjustment band indicators to the turret arrow, you can set the sprinkler arc to 90°, 180°, 270° or 360°. See **Figure 7**.

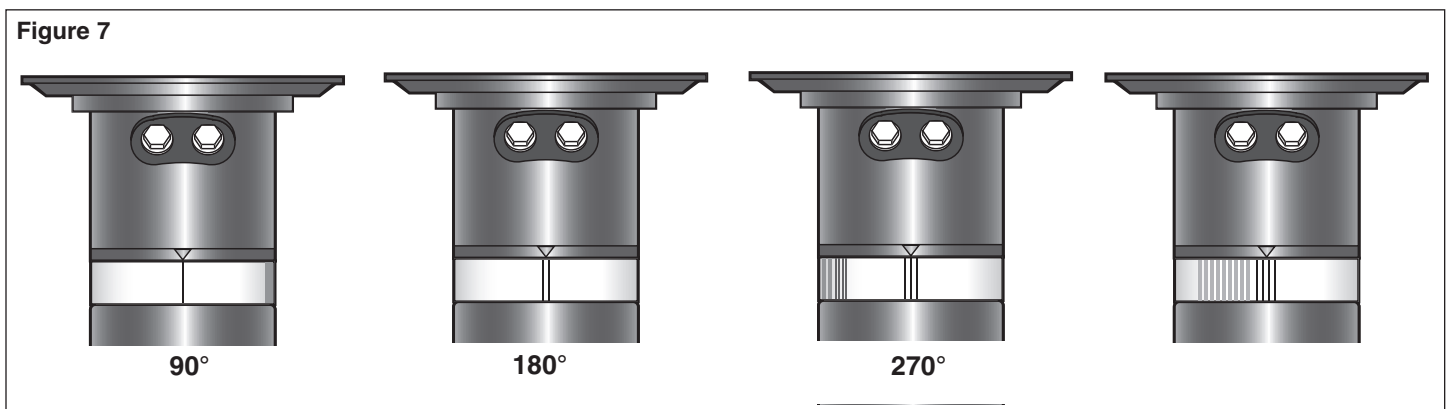

5. Activate the sprinkler to check proper arc setting and readjust as necessary.

Nozzle Trajectory Adjustment Procedure

Note: The nozzle trajectory is factory set at 25 degrees.

1. Insert the multi-purpose tool (P/N 995-83) into the slot provided in the top of the cap. Pull the riser assembly up, then grasp the assembly to hold it in the popped-up position.
2. Remove the cap retaining screw and cap.
3. Using a 5/8" nut driver (P/N 995-99), turn the nozzle/housing assembly left to select 15° trajectory as shown in **Figure 8**. Turn the nozzle/housing assembly right to select 25° trajectory as shown in **Figure 9**.
4. Install the cap making sure the top of the nozzle housing is correctly nested in the cap.
5. Install the cap retaining screw.
6. Activate the sprinkler to check the spray trajectory.

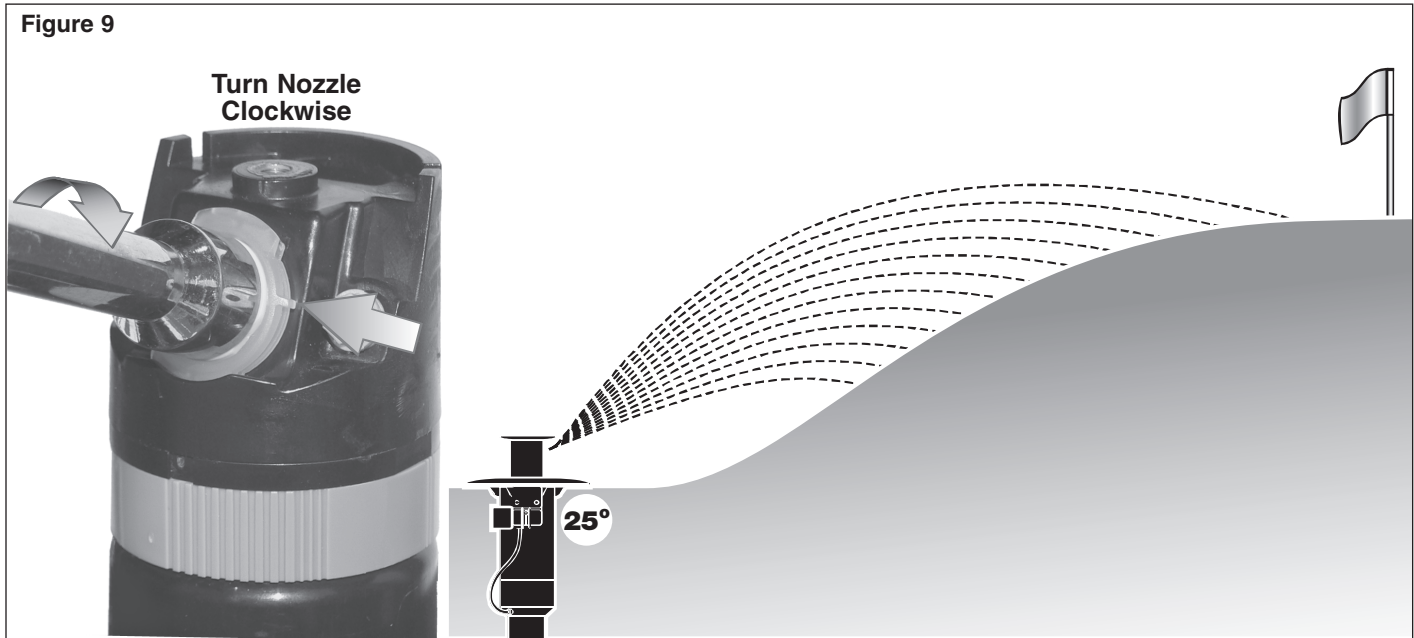
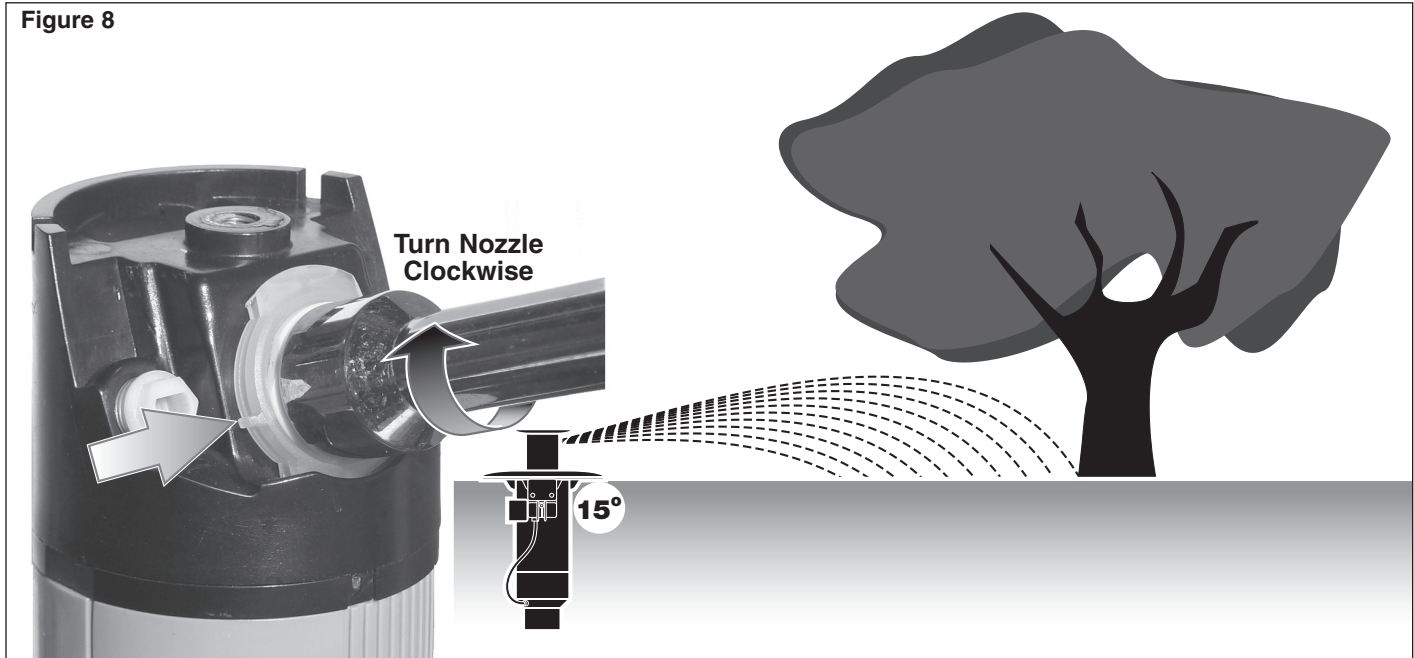

Pilot Valve Operation (Electric Models Only)

The main function of the pilot valve is to control the operation of the main valve located in the base of the sprinkler body. The main valve is operated by the release of water metered through the pilot valve when it is activated either manually at the sprinkler or by the irrigation system controller.

Another important function of the pilot valve is to regulate the water pressure to the sprinkler nozzle. Pressure regulation compensates for large variations within the system and maintains a constant pressure for optimum sprinkler operation. The pilot valve is factory set to regulate one of four pressure levels 50 psi (3.4 bar), 65 psi (4.5 bar), 80 psi (5.5 bar) or 100 PSI (6.9 bar).

Change the pilot valve operating pressure by loosening the thumb screw that secures the selector lever. Position the selector lever to the desired operating pressure and hand-tighten the nut. See **Figure 10**.

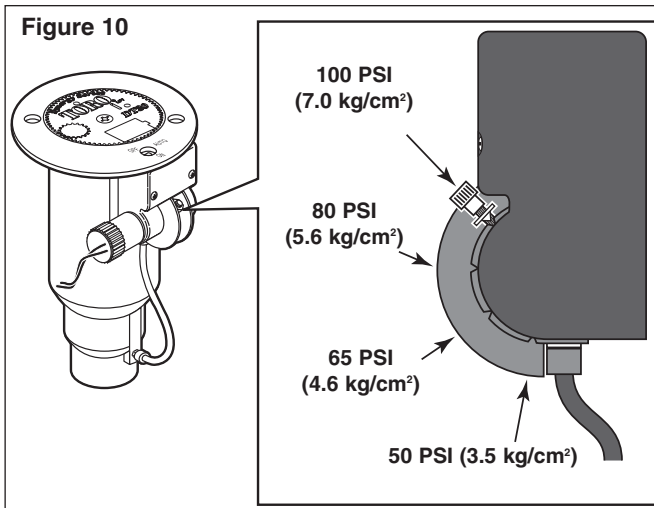

Troubleshooting

Pilot Valve

PROBLEM	POSSIBLE CAUSE – CORRECTIVE ACTION
Sprinkler will not turn on	<ul style="list-style-type: none"> (a) No 24 VAC to solenoid assembly. (Electric Models) <ul style="list-style-type: none"> – Measure voltage with a Digital Volt Meter (DVM). Check wiring and controller program. – Refer to Controller Operating Instructions. (b) Selector cam in "OFF" position. <ul style="list-style-type: none"> – Set to "AUTO" position. (c) Debris in pilot valve assembly. <ul style="list-style-type: none"> – Disassemble and remove all debris. (See Servicing Pilot Valve page 12.) (d) Insufficient pressure in controller supply line and/or sprinkler control tube. (N.C. Models) <ul style="list-style-type: none"> – Check pressure.
Sprinkler will not shut off	<ul style="list-style-type: none"> (a) Constant 24 VAC from controller. (Electric Models) <ul style="list-style-type: none"> – Check for voltage using a DVM. If voltage is present, disconnect wire. If sprinkler closes, service controller. Refer to Controller Service Manual. (b) Selector cam in manual "ON" position. <ul style="list-style-type: none"> – Set to "AUTO" or "OFF" position. (c) Debris in pilot valve assembly. <ul style="list-style-type: none"> – Disassemble and remove all debris. (See Servicing Pilot Valve page 12.) (d) Constant pressure from controller. (N.C. Models) <ul style="list-style-type: none"> – Check pilot valve at controller for constant flow. – Check elevation differential. Valve elevation should not exceed 0' above controller elevation or 70' (21.3 m) below controller elevation.
Sprinkler Mechanism	
PROBLEM	POSSIBLE CAUSE – CORRECTIVE ACTION
Sprinkler won't rotate	<ul style="list-style-type: none"> (a) Debris wedged between stator and turbine. <ul style="list-style-type: none"> – Remove obstruction. (b) Drive assembly defective. <ul style="list-style-type: none"> – Replace drive assembly. (c) Nozzle base assembly defective. <ul style="list-style-type: none"> – Replace nozzle base assembly.
Head sticks up	<ul style="list-style-type: none"> (a) Dirt in riser assembly. <ul style="list-style-type: none"> – Flush out. (See Flushing Procedure on page 12.) (b) Damaged or missing return spring. <ul style="list-style-type: none"> – Replace. (c) Damaged riser. <ul style="list-style-type: none"> – Replace.
Poor distribution pattern	<ul style="list-style-type: none"> (a) Nozzle plugged with debris. <ul style="list-style-type: none"> – Clean or replace nozzle. (b) Nozzle orifice damaged. <ul style="list-style-type: none"> – Replace nozzle. (c) Low operating pressure. <ul style="list-style-type: none"> – Determine why system overloaded and correct.

Main Valve

PROBLEM	POSSIBLE CAUSE – CORRECTIVE ACTION
Valve won't close (Electric)	<ul style="list-style-type: none">(a) Continuous 24 VAC to sprinkler.<ul style="list-style-type: none">– Check controller for voltage source.(b) Leak in pilot valve assembly.<ul style="list-style-type: none">– Replace pilot valve assembly.(c) Plugged supply screen on piston.<ul style="list-style-type: none">– Clean or replace screen.(d) Manual control selector on pilot valve assembly turned to "ON" position.<ul style="list-style-type: none">– Turn to "AUTO" position.(e) Plunger movement restricted.<ul style="list-style-type: none">– Inspect and clean or replace.(f) Valve cylinder misaligned with sprinkler body communication tube.<ul style="list-style-type: none">– Remove valve assembly and install correctly.(g) Foreign object keeping valve from seating.<ul style="list-style-type: none">– Remove, clean and check valve for damage. Replace if necessary.(h) Damaged piston seal or piston assembly.<ul style="list-style-type: none">– Replace valve assembly.
Valve won't close (Hydraulic)	<ul style="list-style-type: none">(a) Leak in control tubing.<ul style="list-style-type: none">– Isolate and repair.(b) Pilot valve leak in controller.<ul style="list-style-type: none">– Confirm by observing constant dripping from discharge line of controller. Refer to Controller Service Manual.(c) Valve cylinder misaligned with sprinkler body communication tube.<ul style="list-style-type: none">– Remove valve assembly and install correctly.(d) Foreign object keeping valve from seating.<ul style="list-style-type: none">– Remove, clean and check valve for damage. Replace if necessary.(e) Damaged piston seal or piston assembly.<ul style="list-style-type: none">– Replace valve assembly.
Valve won't open (Electric)	<ul style="list-style-type: none">(a) Control (field) wires severed.<ul style="list-style-type: none">– Isolate and repair.(b) No power to controller.<ul style="list-style-type: none">– Establish controller power.(c) No power from controller to solenoid.<ul style="list-style-type: none">– Check for blown fuse and replace.(d) Manual control selector on pilot valve assembly turned to "OFF" position.<ul style="list-style-type: none">– Turn to "AUTO" position.(e) Pilot valve solenoid inoperative.<ul style="list-style-type: none">– Remove and replace.(f) Pilot valve plunger movement restricted.<ul style="list-style-type: none">– Inspect, clean and/or replace.(g) No supply from main valve.<ul style="list-style-type: none">– Debris in control tube, main valve assembly and/or communication passages in body. Flush thoroughly.
Valve won't open (Hydraulic)	<ul style="list-style-type: none">(a) Plugged controller discharge line or discharge port in pilot valve.<ul style="list-style-type: none">– Verify by checking for discharge at discharge line when station is activated. If no discharge, refer to Controller Service Manual.
Sprinkler Weeping (Slow leak in valve)	<ul style="list-style-type: none">(a) Damaged or blocked valve seat.<ul style="list-style-type: none">– Remove blockage and, if necessary, replace valve assembly.(b) Damaged piston seal or piston assembly.<ul style="list-style-type: none">– Replace valve assembly.(c) Low pressure on supply line .<ul style="list-style-type: none">– Check for low pressure reason and correct.(d) Elevation of normally closed sprinkler exceeds 75' (22.9 m) differential.
Several valves on different stations fail to close (Hydraulic)	<ul style="list-style-type: none">(a) Control tubing leak which lowers supply pressure to other stations.<ul style="list-style-type: none">– Turn controller from station to station until a station is reached where only valves on that station stay open. The leak would be in the tubing on that station. Isolate and repair.(b) Leak in supply line to controller.<ul style="list-style-type: none">– Verify by checking pressure in all control lines.(c) Leak in controller pilot valve.<ul style="list-style-type: none">– Verify by constant discharge from controller.(d) Plugged supply line filter.<ul style="list-style-type: none">– Replace filter if more than 3 psi (0.21 bar) differential exists.



WARNING

NEVER STAND OR LEAN OVER THE SPRINKLER WHILE THE IRRIGATION SYSTEM IS BEING FILLED, DURING MANUAL OR AUTOMATIC OPERATION OR WHEN PERFORMING SPRINKLER SERVICE PROCEDURES. DIRECT CONTACT WITH IRRIGATION SPRAY, A FAILED OR IMPROPERLY INSTALLED SPRINKLER CONNECTION OR SPRINKLER COMPONENTS FORCIBLY EJECTED UPWARD UNDER PRESSURE CAN CAUSE SERIOUS INJURY.

Servicing Sprinkler Mechanism

Note: Refer to **Figure 11** for the following procedure.

1. Remove the cap screw (2) and cap (3).

Note: During reassembly, ensure the cap is correctly aligned with main nozzle housing assembly (10).

2. Insert the hooked end of the multi-purpose tool (P/N 995-83) into the snap ring slot (4). Pull the snap ring inward towards the sprinkler assembly, then upward to remove from the groove in body.

Note: During reassembly, ensure the snap ring is correctly installed and fully seated in the sprinkler body.

3. Insert the hooked end of the tool into the slot provided in the nozzle base above the back nozzle (7) position. Pull the riser assembly until enough clearance to handle. Hold onto the riser body (13) and carefully extract it from the sprinkler body.

▲ CAUTION: The seal/retainer (5) will eject (caused by the decompressing spring [6]) as it clears the sprinkler body.

4. Three small tabs are provided on the edge of the multi-purpose tool. Insert tabs into the debris filter screen (17). Holding the plastic base of riser assembly, turn the screen counterclockwise to remove.

5. Remove the variable stator (16) from riser assembly.

6. Loosen the drive assembly retaining screw (14) 6–7 turns and pull the drive assembly (15) using a pair of pliers. See **Figure 12**.

Note: Do not remove the retaining screw completely as it is easily misplaced.

▲ CAUTION: When removing or installing the drive assembly, do not use the turbine to pull the drive assembly. Use the drive assembly body to extract it out. Failure to comply may cause separation of the drive assembly components.

Note: During reassembly, ensure drive assembly is properly aligned with the retaining screw.

7. Using a 5/8" nut driver (P/N 995-99), unscrew main nozzle (12) from nozzle assembly.

8. Using a 5/16" nut driver (P/N 995-105), unscrew the inner (8) and intermediate (9) nozzles as well as the back nozzle plugs.

9. Thoroughly clean and inspect all parts and replace as necessary. Reassemble in reverse order.

Figure 11

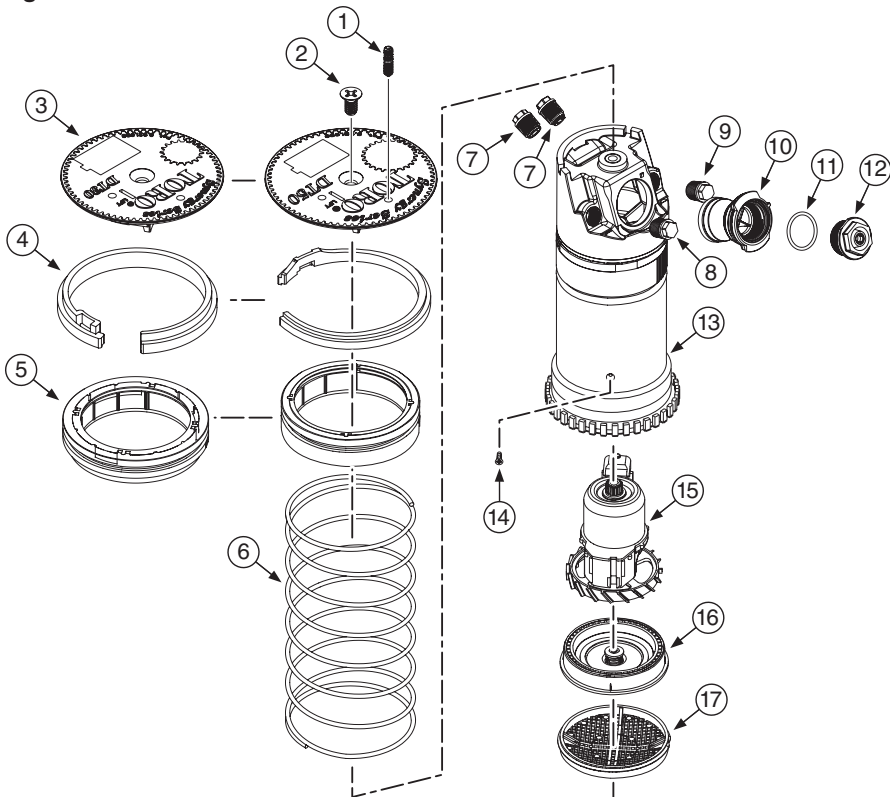
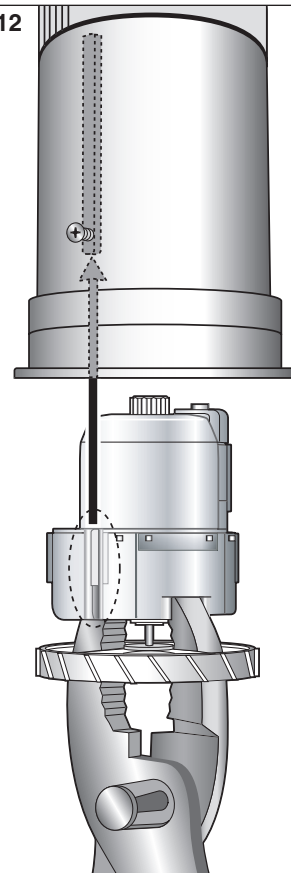

Figure 12



Servicing Main Valve



WARNING

IF THE VALVE SNAP RING IS DIFFICULT TO REMOVE, RESIDUAL WATER PRESSURE MAY BE REMAINING IN THE SYSTEM. TO PREVENT POSSIBLE SERIOUS INJURY DUE TO VALVE BEING EJECTED UPWARD UNDER PRESSURE, CONFIRM THE FOLLOWING CONDITIONS EXIST PRIOR TO REMOVING THE SNAP RING AND VALVE.

- A. WATER SUPPLY TO SPRINKLER IS SHUT OFF AT SOURCE.
- B. ALL PRESSURE IS BLED FROM SYSTEM, INCLUDING CONTROL TUBES.
- C. AC POWER IS DISCONNECTED AT SOURCE.

1. See **Warning** above. To remove valve assembly, squeeze snap ring ears together with snap ring pliers (P/N 995-100) and remove snap ring from sprinkler body. See **Figure 13**.

2. Use valve removal tool P/N 995-08 for DT35 or 995-09 for DT55 to remove valve assembly from base of sprinkler body. Valve removal tool is inserted into sprinkler body and pushed through valve ribs. A slight twist will catch tool under ribs enabling valve removal by pulling straight up and out. See **Figure 14**.

Note: If valve removal tool is not available, use snap ring pliers to grasp rib of valve cylinder assembly and pull up and out of sprinkler body.

3. Reinstall valve assembly using valve insertion tool P/N 995-76 for DT35 or 995-101 for DT55 as follows:

- Load snap ring onto insertion tool carrier with stepped side against carrier as shown in **Figure 15**. While holding snap ring in compressed position, slide retainer clip in to hold snap ring ears
- Load valve assembly on carrier as shown.
- Locate position of communication tube in bottom of sprinkler body and orient insertion tool accordingly.
- Insert tool straight down into sprinkler body aligning bosses on t-handle with holes on sprinkler body flange. When valve assembly clears vertical side wall ribs inside body, pull up on snap ring release mechanism (DT55 models only) and press valve assembly into position. Snap ring will lock into groove when properly installed. Remove insertion tool and check snap ring to confirm that it is fully seated in groove

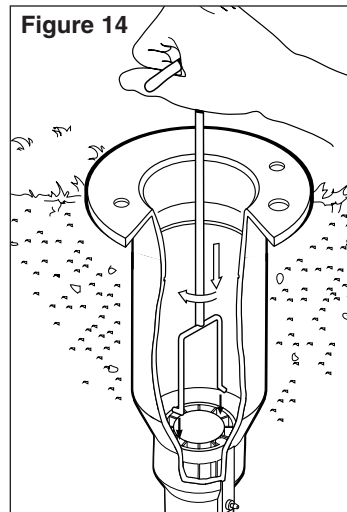
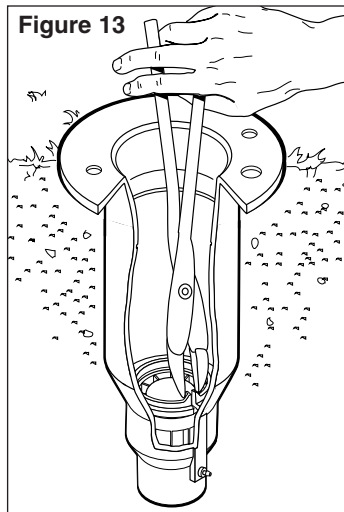
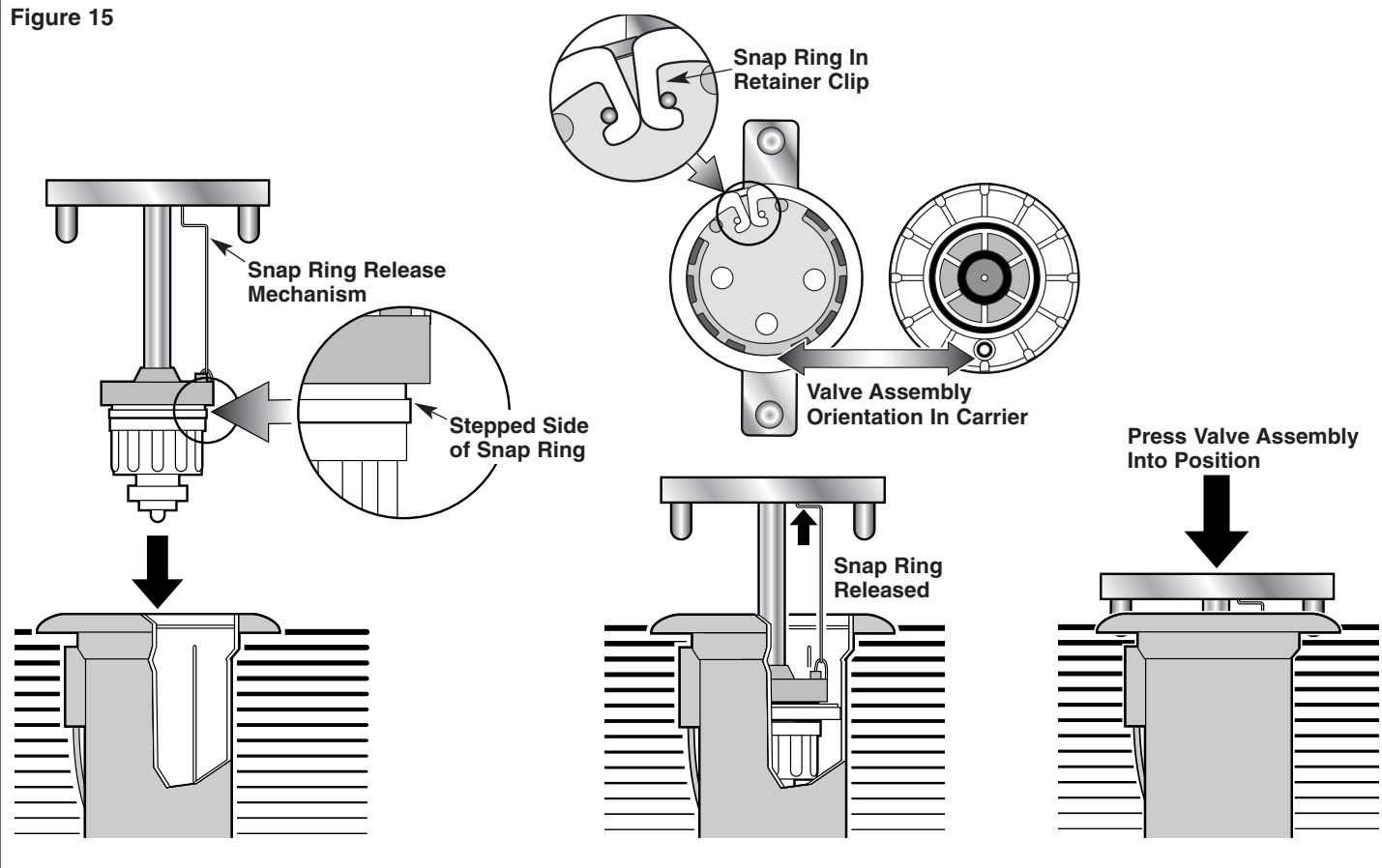

Figure 15



Servicing Pilot Valve



WARNING

NEVER STAND OR LEAN OVER THE SPRINKLER WHILE THE IRRIGATION SYSTEM IS BEING FILLED, DURING MANUAL OR AUTOMATIC OPERATION OR WHEN PERFORMING SPRINKLER SERVICE PROCEDURES. DIRECT CONTACT WITH IRRIGATION SPRAY, A FAILED OR IMPROPERLY INSTALLED SPRINKLER CONNECTION OR SPRINKLER COMPONENTS FORCIBLY EJECTED UPWARD UNDER PRESSURE CAN CAUSE SERIOUS INJURY.

Note: Refer to **Figure 16** for the following procedure.

1. Make sure that the water supply to sprinkler is positively shut off and any residual pressure has been bled off. If the sprinkler is pressurized, main valve will open when the pilot valve is disconnected from control tube.
2. Carefully remove turf and soil from the side of the sprinkler to expose pilot valve and control tubing.
3. Remove the two retaining screws from the pilot valve housing.
4. Pull the pilot valve assembly away from the sprinkler body and cut the control tubing just below tube retainer. Unless pilot valve has been previously removed, control tubing length will be sufficient for re-connection.
5. Remove tube retainer and remaining piece of control tubing from valve body fitting.
6. Remove the solenoid (1, 2 or 3) by turning it counterclockwise.
7. Remove the retaining nut (18) and washer (17) from the pressure adjuster (11) and pull the pilot valve body assembly out of housing (16).
8. Remove diaphragm assembly (15), piston (14), spring (13), traveling adjuster (12), pressure adjuster (11) and o-ring (7).

Figure 16

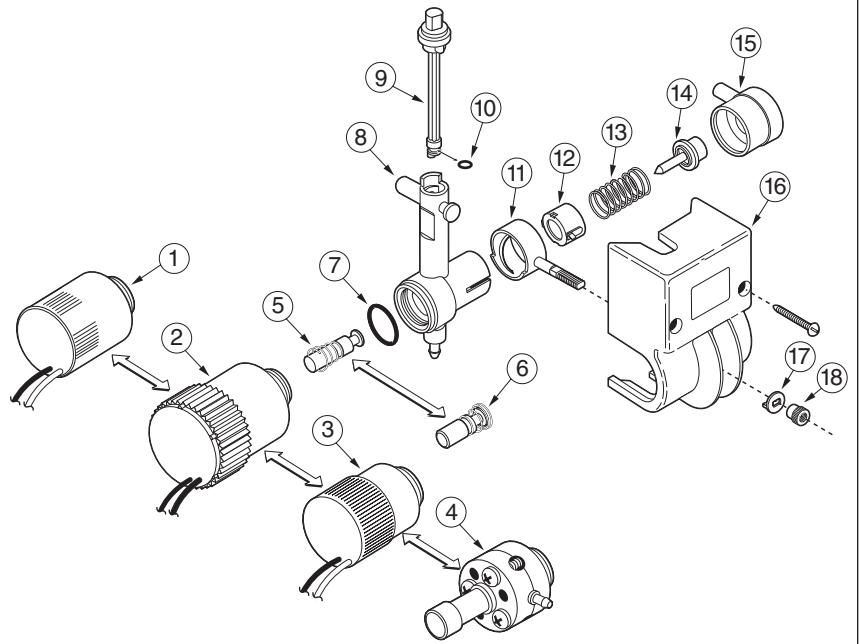

9. Remove selector shaft assembly (9) and plunger assembly (5). (The selector shaft retains the plunger in the valve body.)
10. Thoroughly clean and inspect all parts. Replace damaged parts as necessary and reassemble in reverse order.

Note: Refer to Illustrated Parts Breakout Book, form number 368-0044 for service part numbers.

Flushing Sprinkler



WARNING

NEVER STAND OR LEAN OVER THE SPRINKLER WHILE THE IRRIGATION SYSTEM IS BEING FILLED, DURING MANUAL OR AUTOMATIC OPERATION OR WHEN PERFORMING SPRINKLER SERVICE PROCEDURES. DIRECT CONTACT WITH IRRIGATION SPRAY, A FAILED OR IMPROPERLY INSTALLED SPRINKLER CONNECTION OR SPRINKLER COMPONENTS FORCIBLY EJECTED UPWARD UNDER PRESSURE CAN CAUSE SERIOUS INJURY.

1. With sprinkler operating, carefully step down on center of cap several times. Water will flow around riser and flush out debris.
2. Cycle sprinkler on and off several times to check for proper retraction. Cap should be even with top of body flange when fully retracted. If riser sticks in up position, check for debris lodged between riser and body. Flush out all debris. Remove sprinkler mechanism if necessary.